

<i>RM</i>	<i>RMB</i>	<i>RMBP</i>	<i>RMS</i>	<i>S</i>
<i>S110 - x4</i> <i>S80 - x12</i> <i>W30 - x14</i> <i>W16 - x32</i> <i>P - x32</i> <i>K10 - x20</i> <i>G - x3</i> <i>INBUS - x1</i>	<i>S110 - x8</i> <i>S80 - x16</i> <i>S50 - x1</i> <i>W30 - x14</i> <i>W16 - x32</i> <i>P - x32</i> <i>K10 - x28</i> <i>G - x3</i> <i>INBUS - x1</i>	<i>S110 - x8</i> <i>S80 - x16</i> <i>S50 - x1</i> <i>W30 - x14</i> <i>W16 - x32</i> <i>P - x32</i> <i>K10 - x28</i> <i>K8 - X68</i> <i>G - x3</i> <i>INBUS - x1</i>	<i>S110 - x4</i> <i>S80 - x12</i> <i>W30 - x14</i> <i>W16 - x32</i> <i>P - x32</i> <i>K10 - x20</i> <i>G - x3</i> <i>INBUS - x1</i>	<i>S50 - x10</i> <i>W16 - x16</i> <i>G - x1</i>

<i>DMS</i>	<i>DMSB</i>	<i>DMSBP</i>	<i>DMSS</i>	<i>DM</i>
<i>S110 - x4</i> <i>S80 - x12</i> <i>W30 - x14</i> <i>W16 - x32</i> <i>P - x32</i> <i>K10 - x24</i> <i>G - x3</i> <i>INBUS - x1</i>	<i>S110 - x8</i> <i>S80 - x16</i> <i>S50 - x1</i> <i>W30 - x14</i> <i>W16 - x32</i> <i>P - x32</i> <i>K1 - x32</i> <i>G - x3</i> <i>INBUS - x1</i>	<i>S110 - x8</i> <i>S80 - x16</i> <i>S50 - x1</i> <i>W30 - x14</i> <i>W16 - x32</i> <i>P - x32</i> <i>K1 - x36</i> <i>K2 - X68</i> <i>G - x3</i> <i>INBUS - x1</i>	<i>S110 - x4</i> <i>S80 - x12</i> <i>W30 - x14</i> <i>W16 - x32</i> <i>P - x32</i> <i>K10 - x24</i> <i>G - x3</i> <i>INBUS - x1</i>	<i>S110 - x4</i> <i>S80 - x12</i> <i>K10 - x24</i> <i>G - x3</i> <i>INBUS - x1</i>

DMSB

60x120 70x140 70x160

80x140 80x160 80x180

80x190 80x200

90x140 90x160 90x180

90x190 90x200

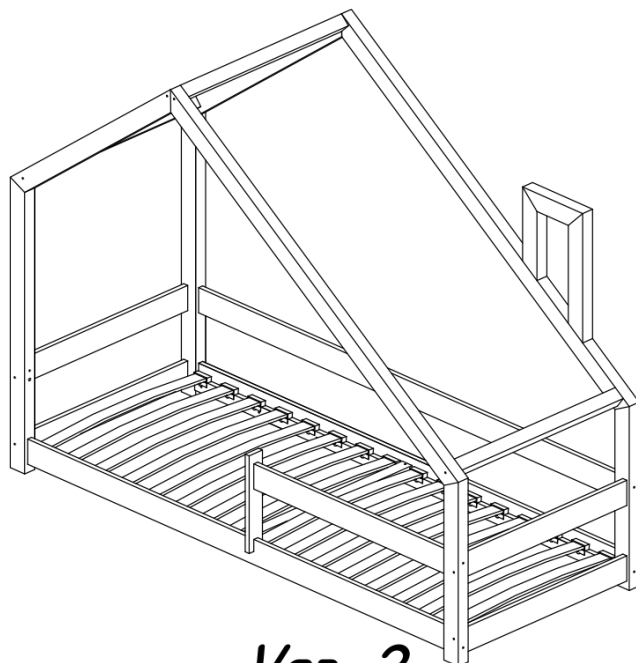

Ver. 2

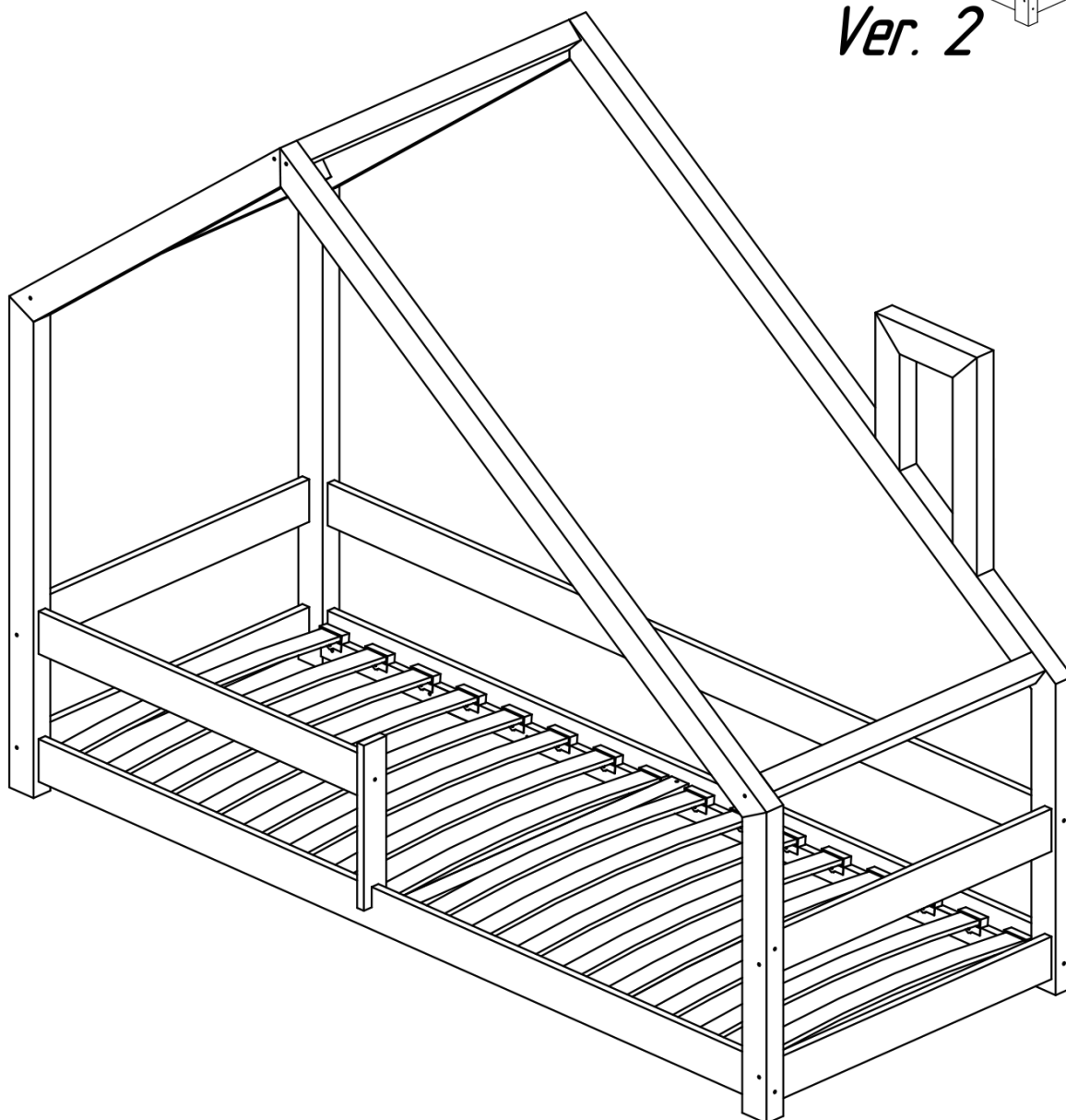

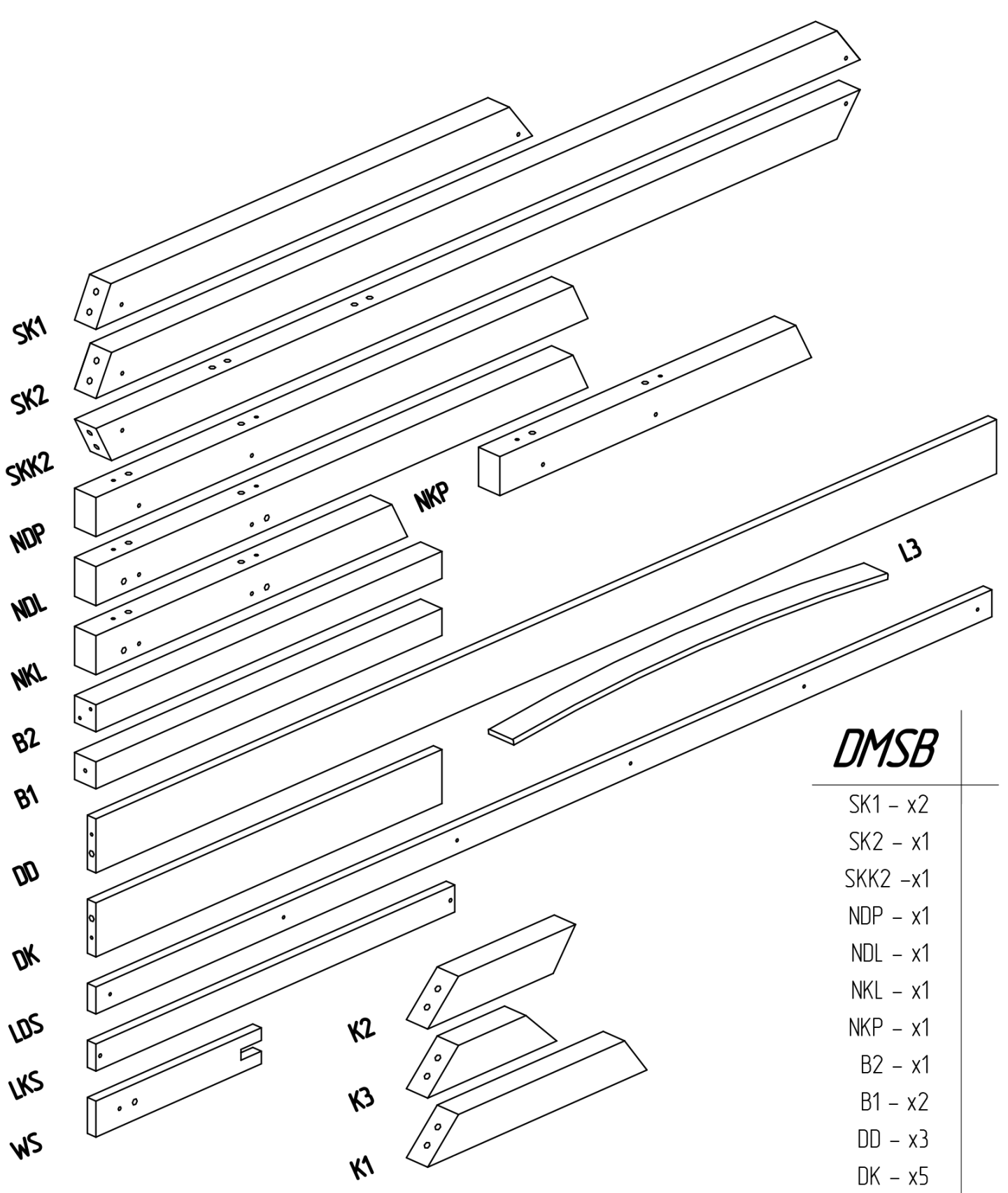

DMSB

- SK1 - x2
- SK2 - x1
- SKK2 - x1
- NDP - x1
- NDL - x1
- NKL - x1
- NKP - x1
- B2 - x1
- B1 - x2
- DD - x3
- DK - x5
- WS - x1
- LDS - x2
- LKS - x1
- ST - x16
- K2 - x1
- K3 - x1
- K1 - x1

- DD - x3*
- DK - x5*
- NDL - x1*
- WS - x1*
- NDP - x1*
- S110 - x8*
- NKL - x1*
- S80 - x7*
- NKP - x1*
- S50 - x1*

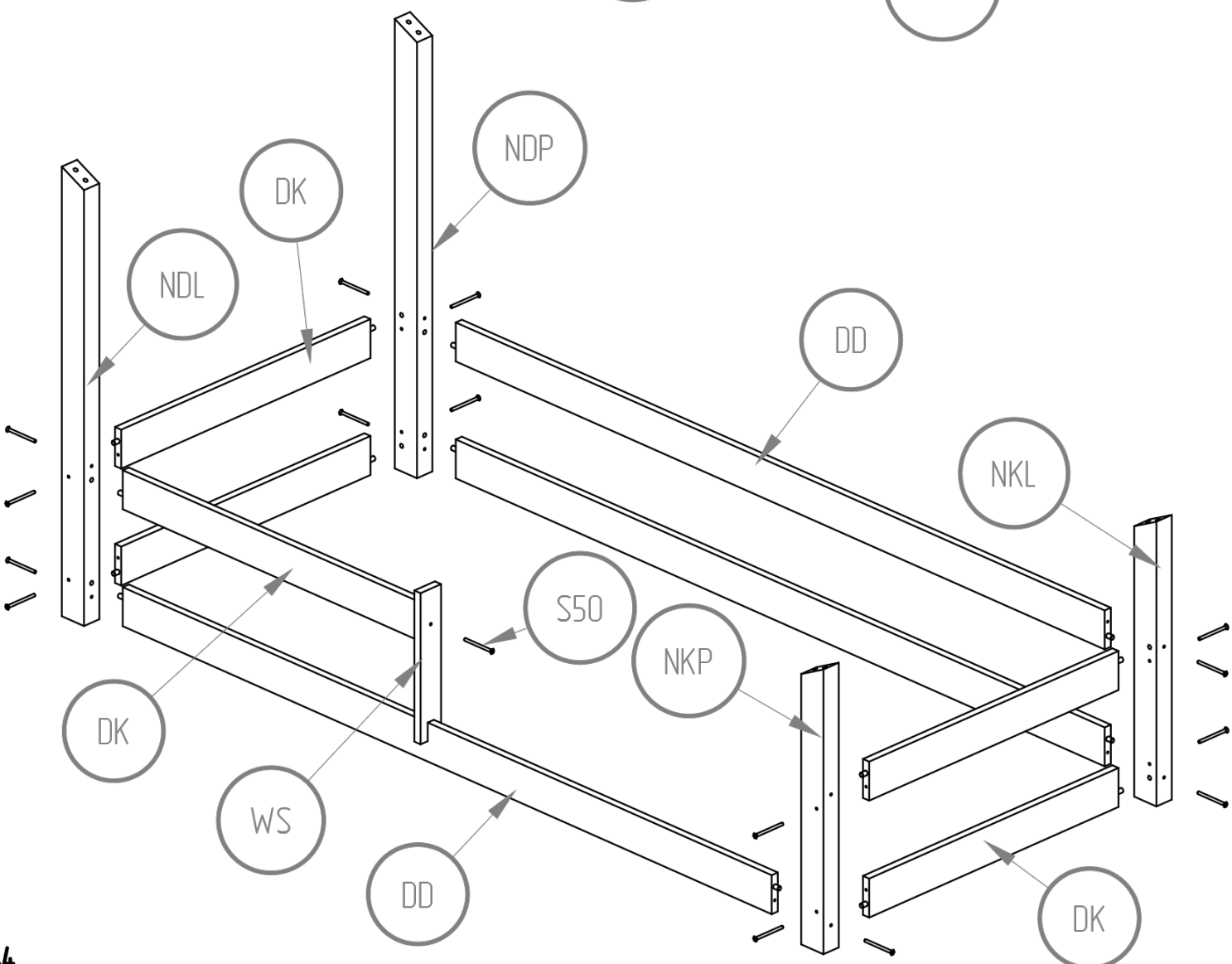
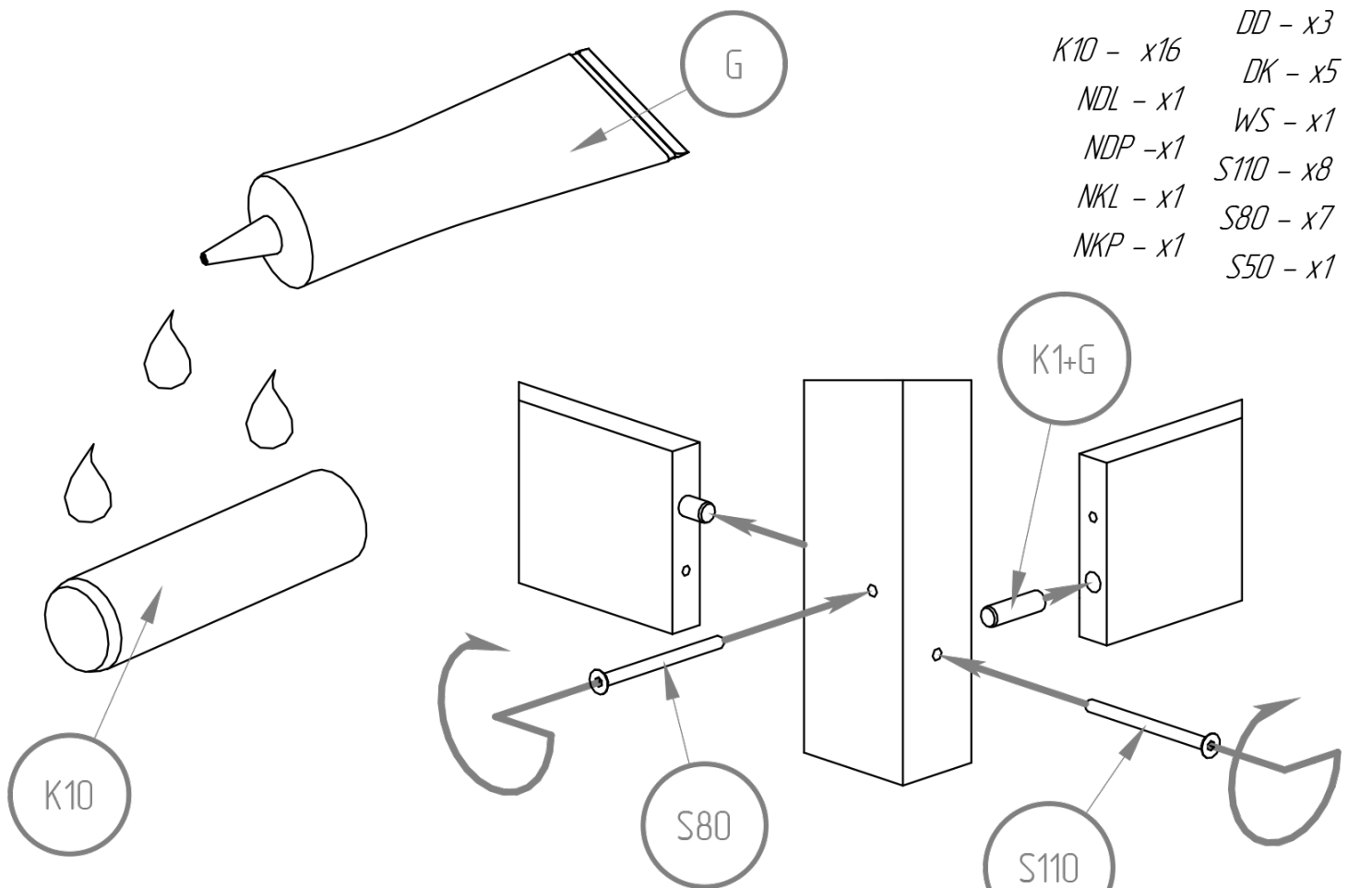

K10 - x12

SK1 - x2

SK2 - x1

SKK2 - x1

L1 - x2

W30 - x12

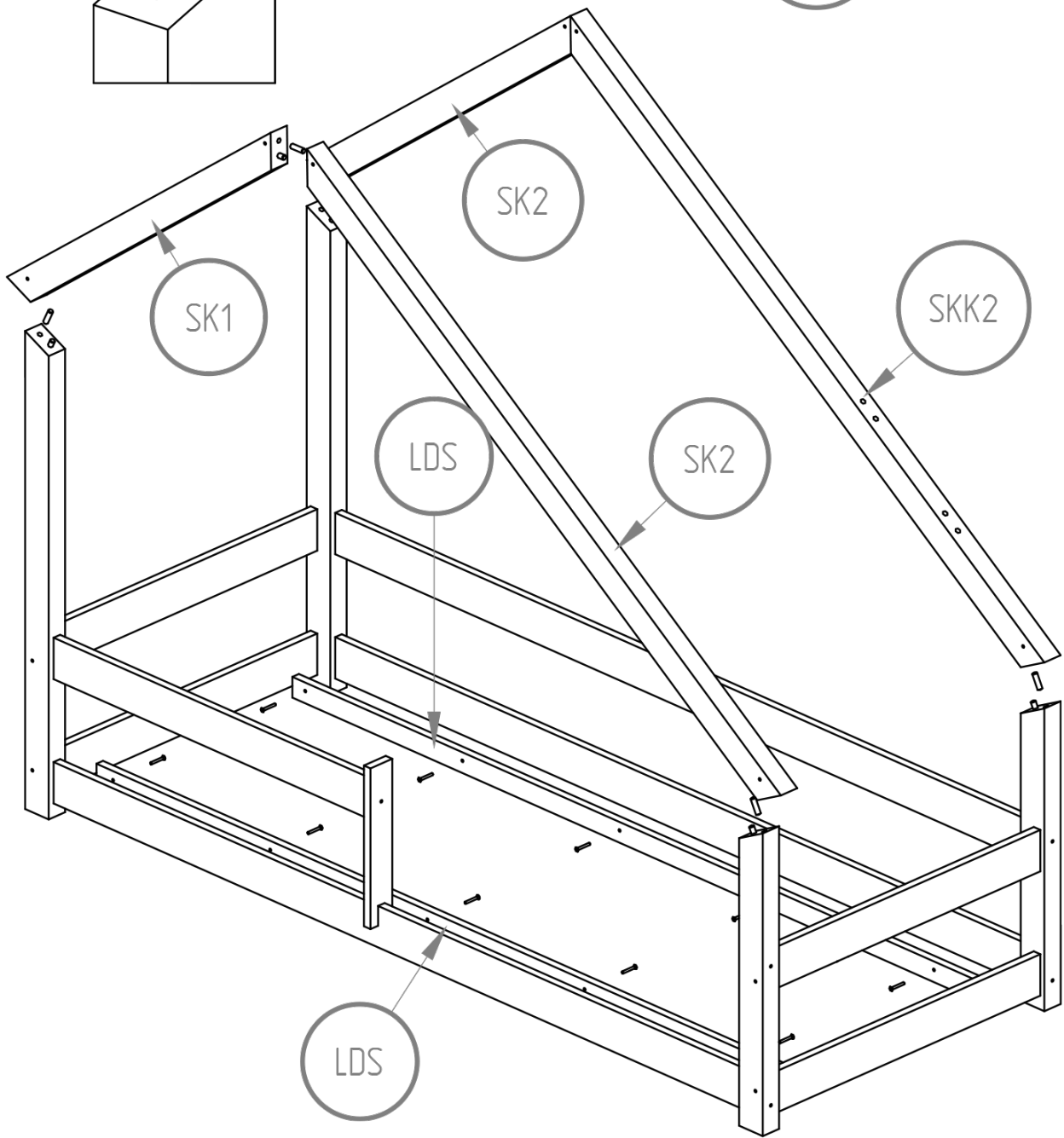
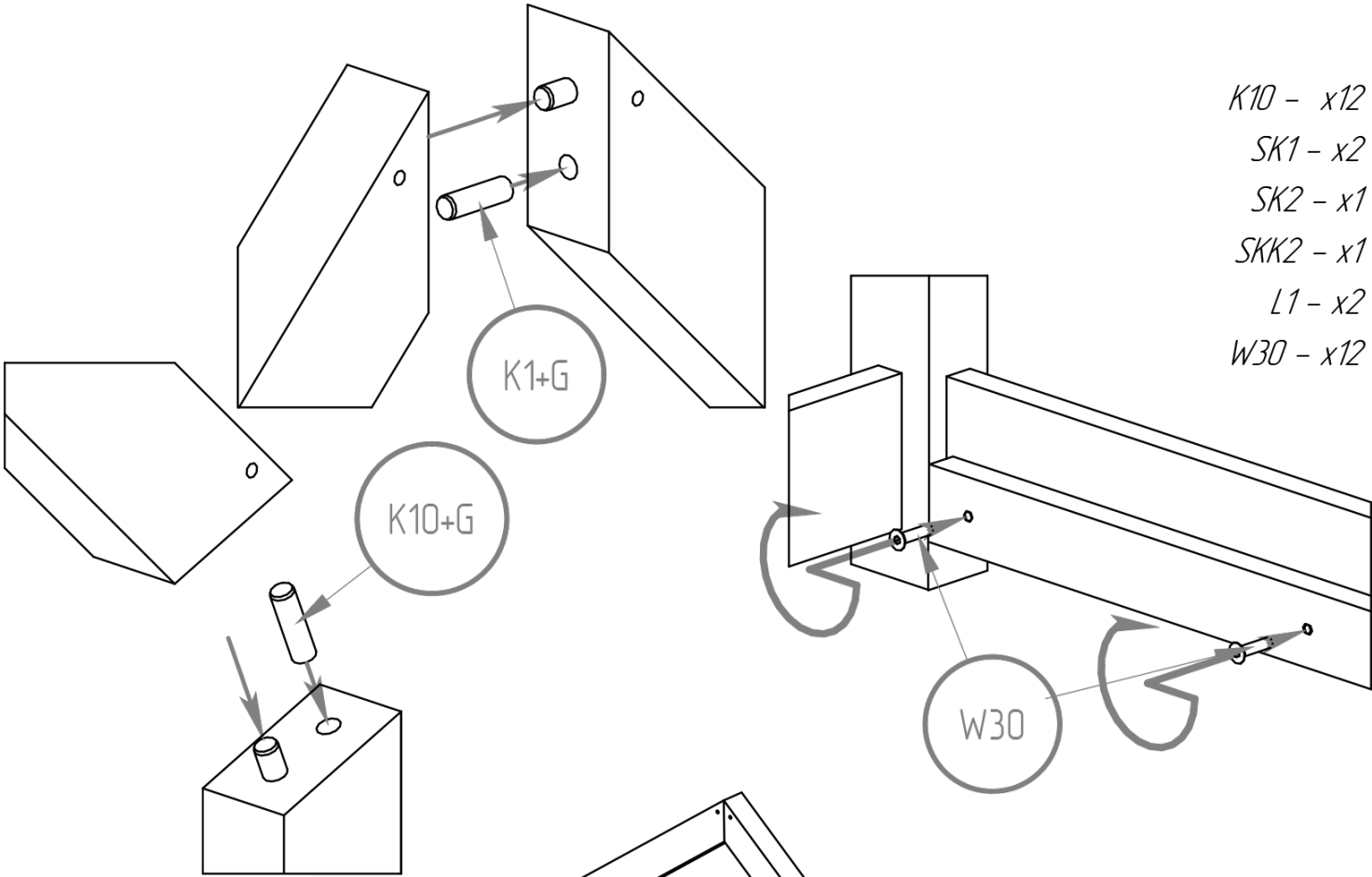

- B2 - x1
- B1 - x2
- LKS - x1
- S80 - x8
- W30 - x2

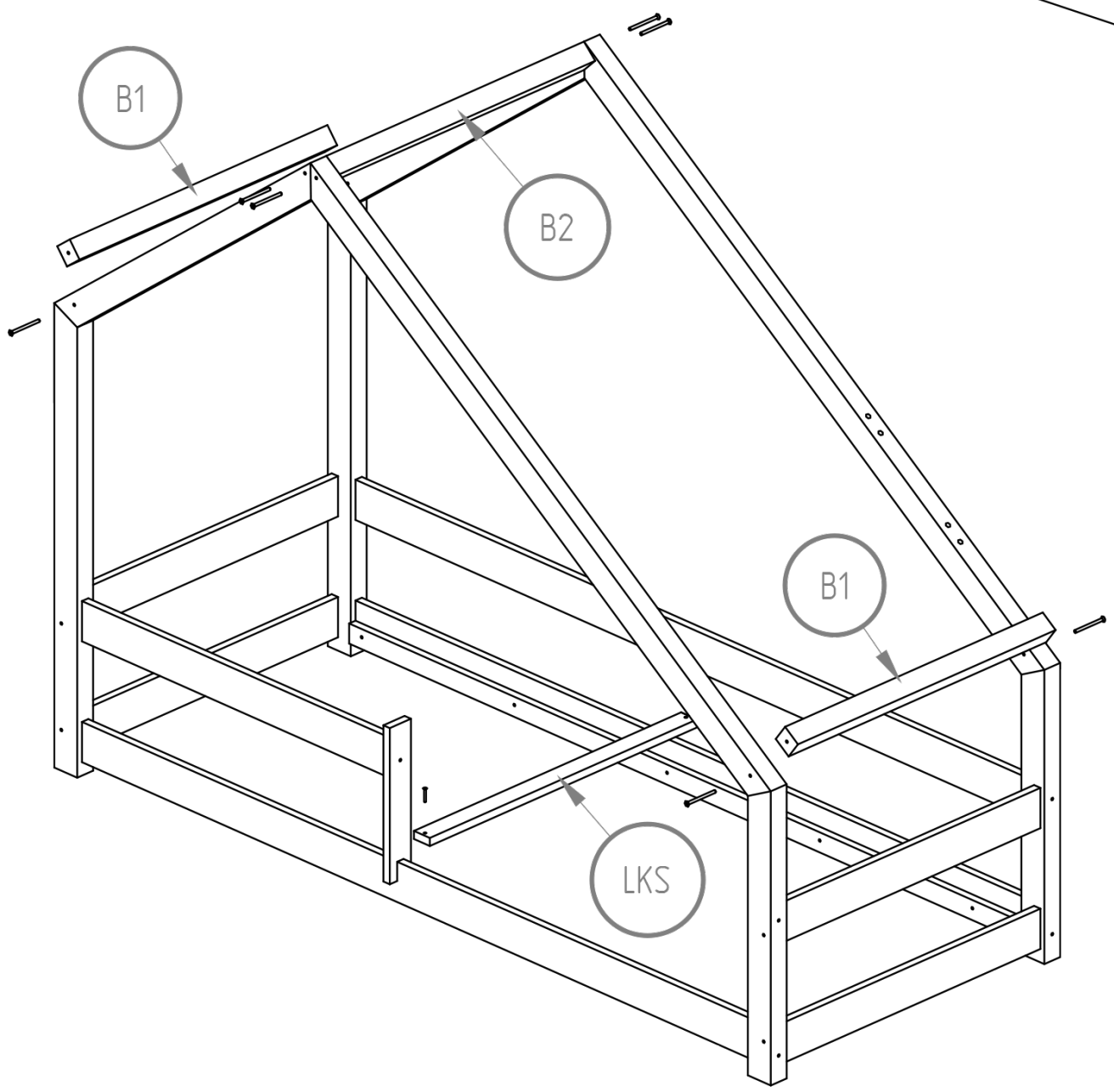
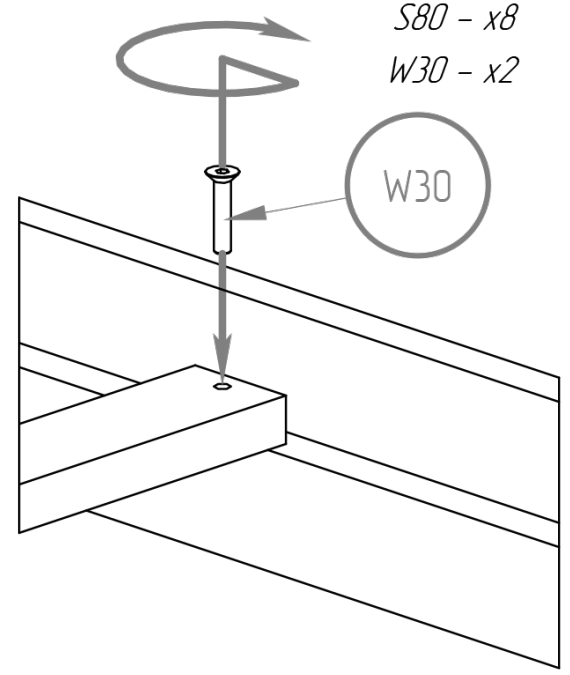
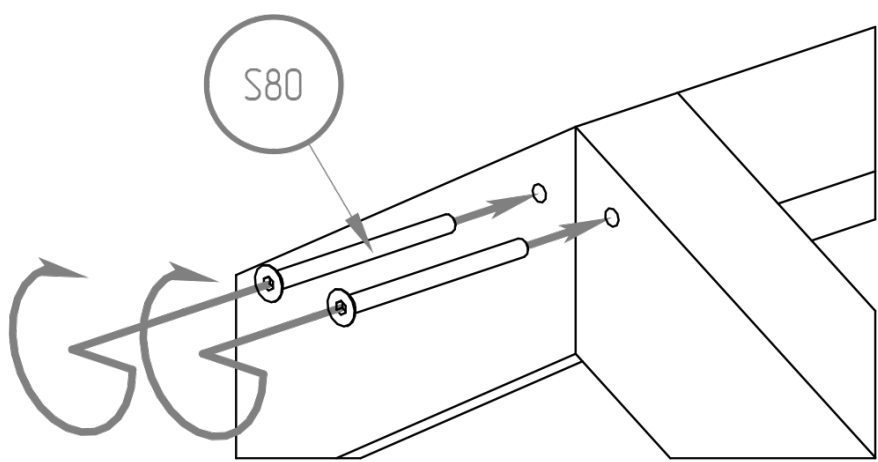

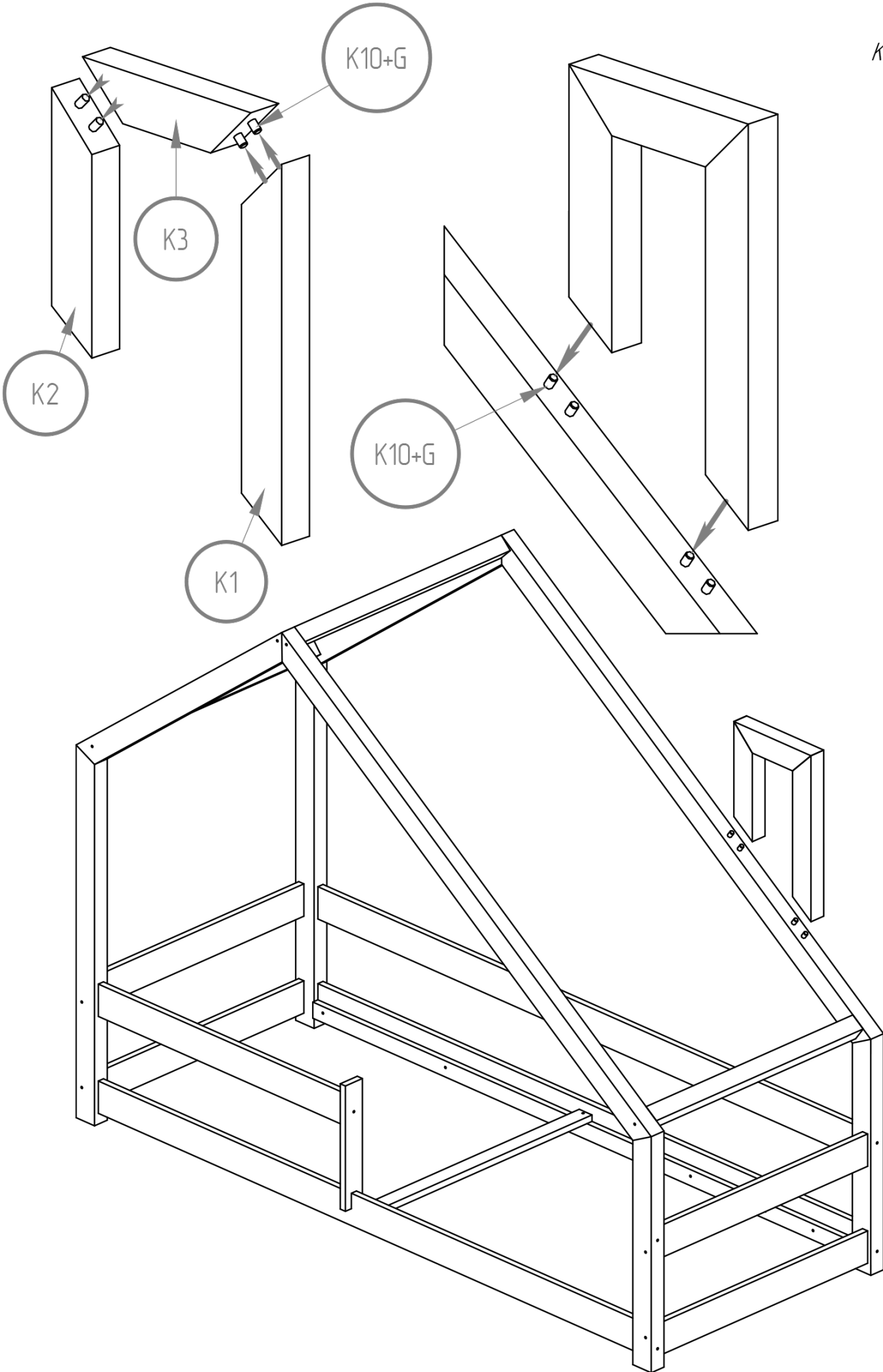

K10 - x8

K1 - x1

K2 - x1

K3 - x1

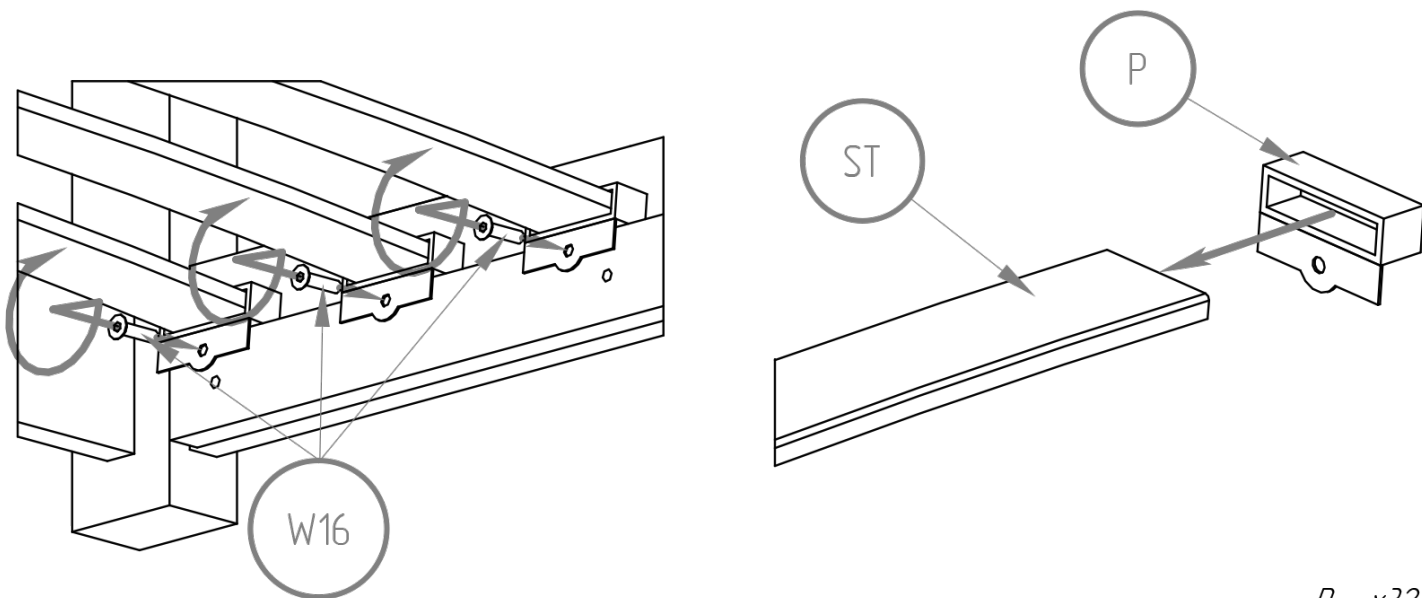

P - x32
ST - x16
W16 - x32

