

<i>M</i>	<i>MB</i>	<i>MBP</i>	<i>MS</i>	<i>NM</i>	<i>S</i>
<i>S110 - x4</i> <i>S80 - x12</i> <i>W30 - x14</i> <i>W16 - x32</i> <i>P - x32</i> <i>K10 - x20</i> <i>G - x3</i> <i>INBUS - x1</i>	<i>S110 - x8</i> <i>S80 - x16</i> <i>S50 - x1</i> <i>W30 - x14</i> <i>W16 - x32</i> <i>P - x32</i> <i>K10 - x28</i> <i>G - x3</i> <i>INBUS - x1</i>	<i>S110 - x8</i> <i>S80 - x16</i> <i>W30 - x14</i> <i>W16 - x32</i> <i>P - x32</i> <i>K10 - x28</i> <i>K8 - x68</i> <i>G - x3</i> <i>INBUS - x1</i>	<i>S110 - x4</i> <i>S80 - x12</i> <i>W30 - x14</i> <i>W16 - x32</i> <i>p - x32</i> <i>K10 - x20</i> <i>G - x3</i> <i>INBUS - x1</i>	<i>S110 - x4</i> <i>S80 - x12</i> <i>K10 - x20</i> <i>G - x3</i> <i>INBUS - x1</i>	<i>S80 - x10</i> <i>W16 - x16</i> <i>G - x1</i>

<i>KM</i>	<i>KMB</i>	<i>KMBP</i>	<i>KMS</i>	<i>TP</i>
<i>S110 - x4</i> <i>S80 - x12</i> <i>W30 - x14</i> <i>W16 - x32</i> <i>p - x32</i> <i>K10 - x16</i> <i>G - x3</i> <i>INBUS - x1</i>	<i>S110 - x8</i> <i>S80 - x16</i> <i>S50 - x1</i> <i>W30 - x1</i> <i>W16 - x32</i> <i>P - x32</i> <i>K10 - x24</i> <i>G - x3</i> <i>INBUS - x1</i>	<i>S110 - x8</i> <i>S80 - x16</i> <i>S50 - x1</i> <i>W30 - x14</i> <i>W16 - x32</i> <i>p - x32</i> <i>K10 - x24</i> <i>K8 - X68</i> <i>G - x3</i> <i>INBUS - x1</i>	<i>S110 - x4</i> <i>S80 - x12</i> <i>W30 - x14</i> <i>W16 - x32</i> <i>P - x32</i> <i>K10 - x16</i> <i>G - x3</i> <i>INBUS - x1</i>	<i>S110 - x8</i> <i>S80 - x2</i> <i>W30 - x14</i> <i>W16 - x32</i> <i>P - x32</i> <i>G - x3</i> <i>INBUS - x1</i>

M

60x120 70x140 70x160

80x140 80x160 80x180

80x190 80x200

90x140 90x160 90x180

90x190 90x200

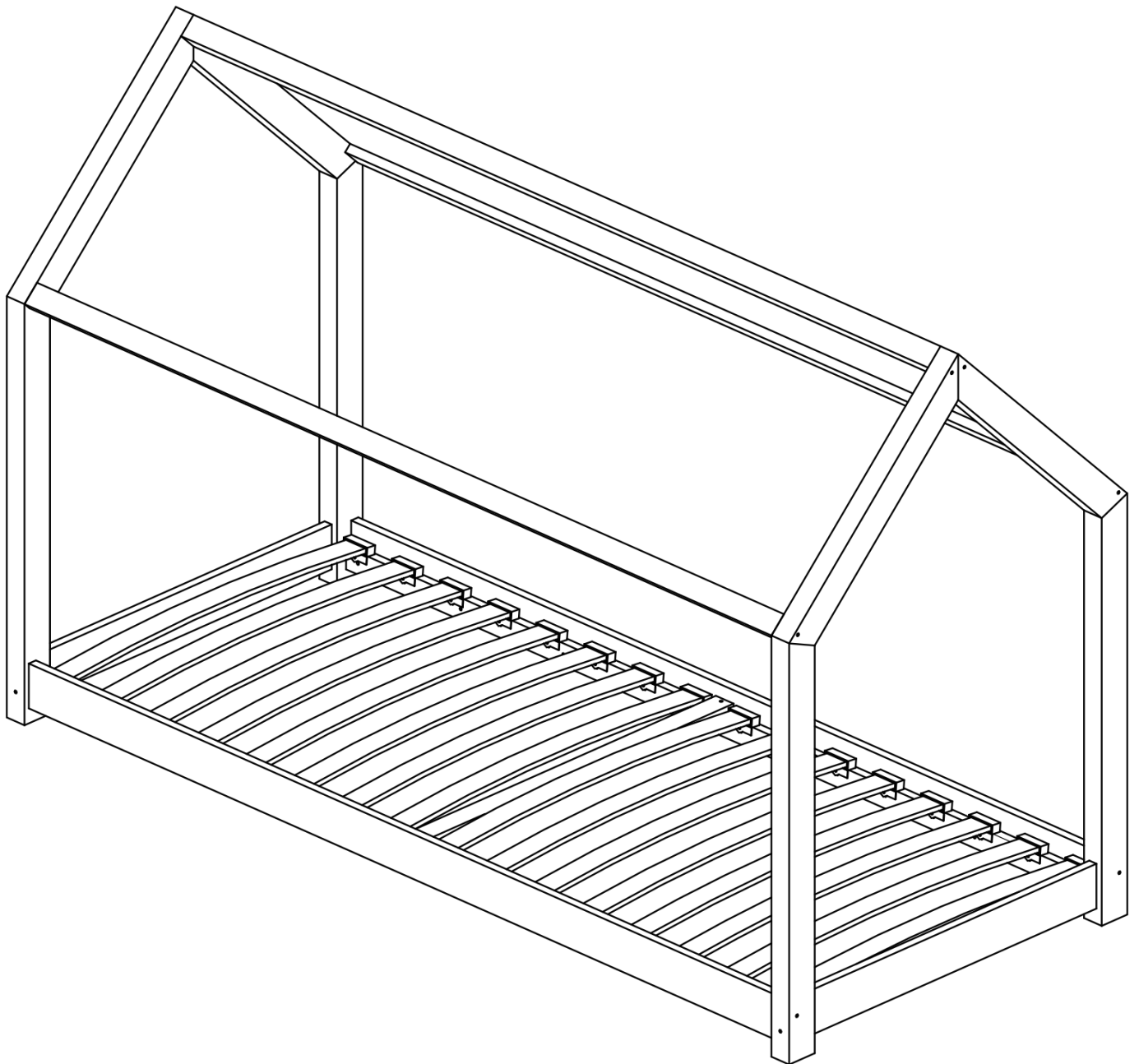

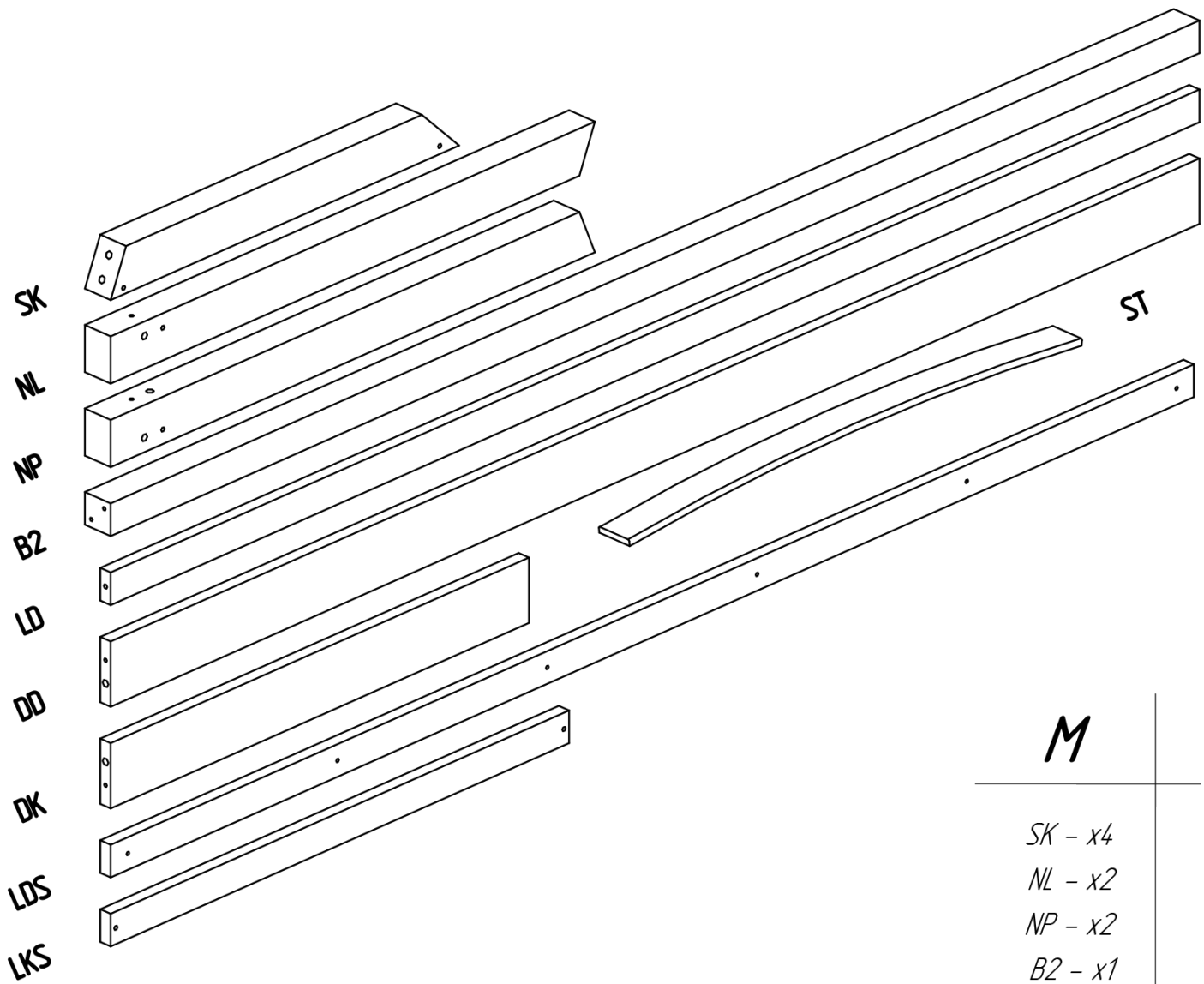

M

- SK - x4
- NL - x2
- NP - x2
- B2 - x1
- LD - x2
- DD - x2
- DK - x2
- LDS - x2
- LKS - x1
- ST - x16

- K10- x8*
- NL - x2*
- NP - x2*
- DD - x2*
- DK - x2*
- S110 - x4*
- S80 - x4*

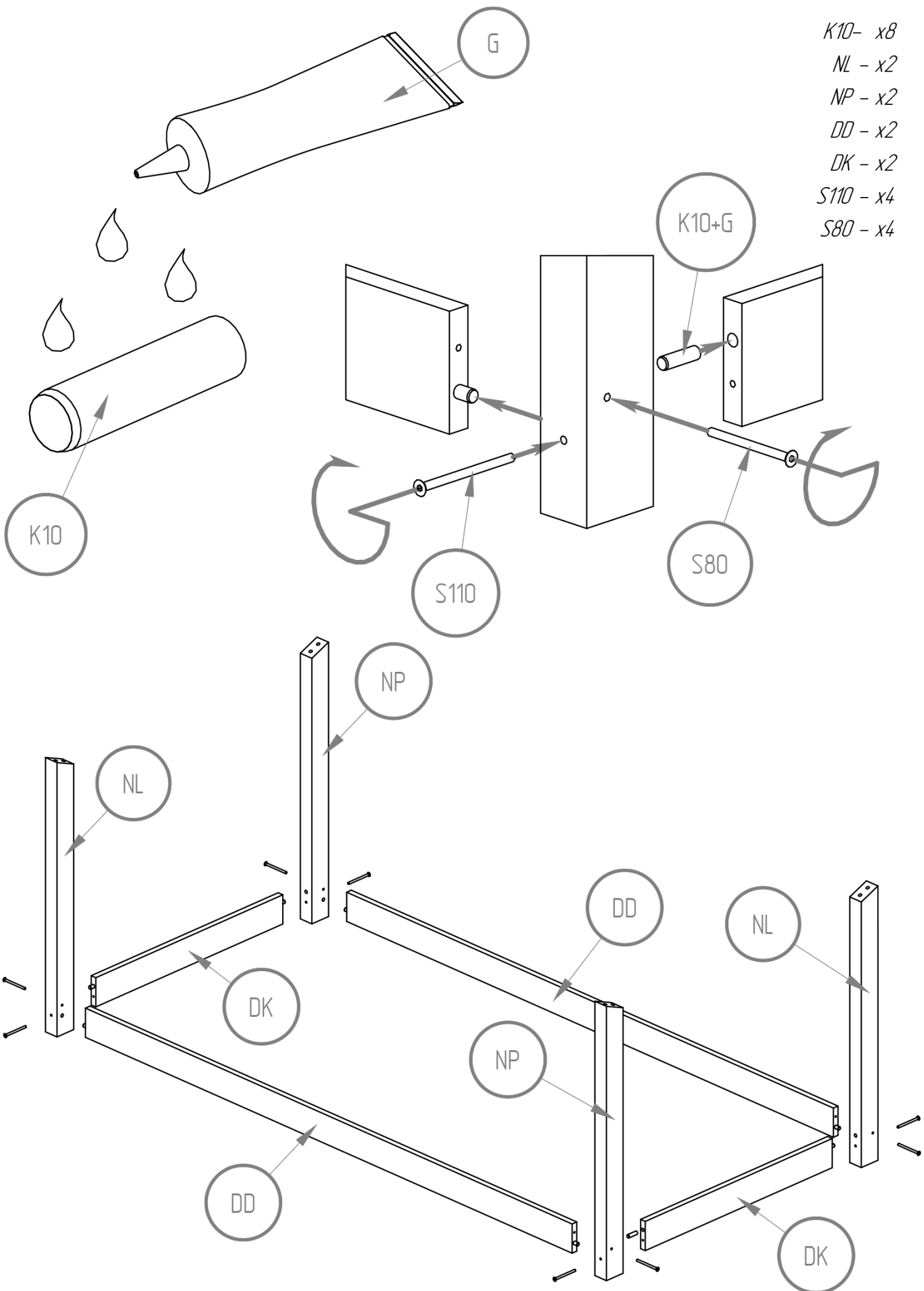

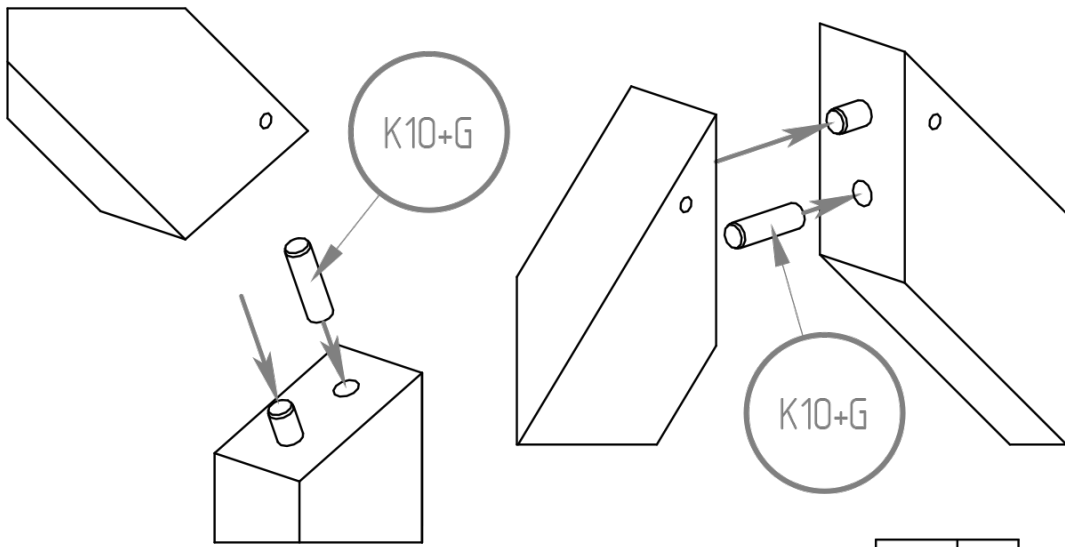

K10 - x12
ST - x4
LDS - x2
W30 - x12

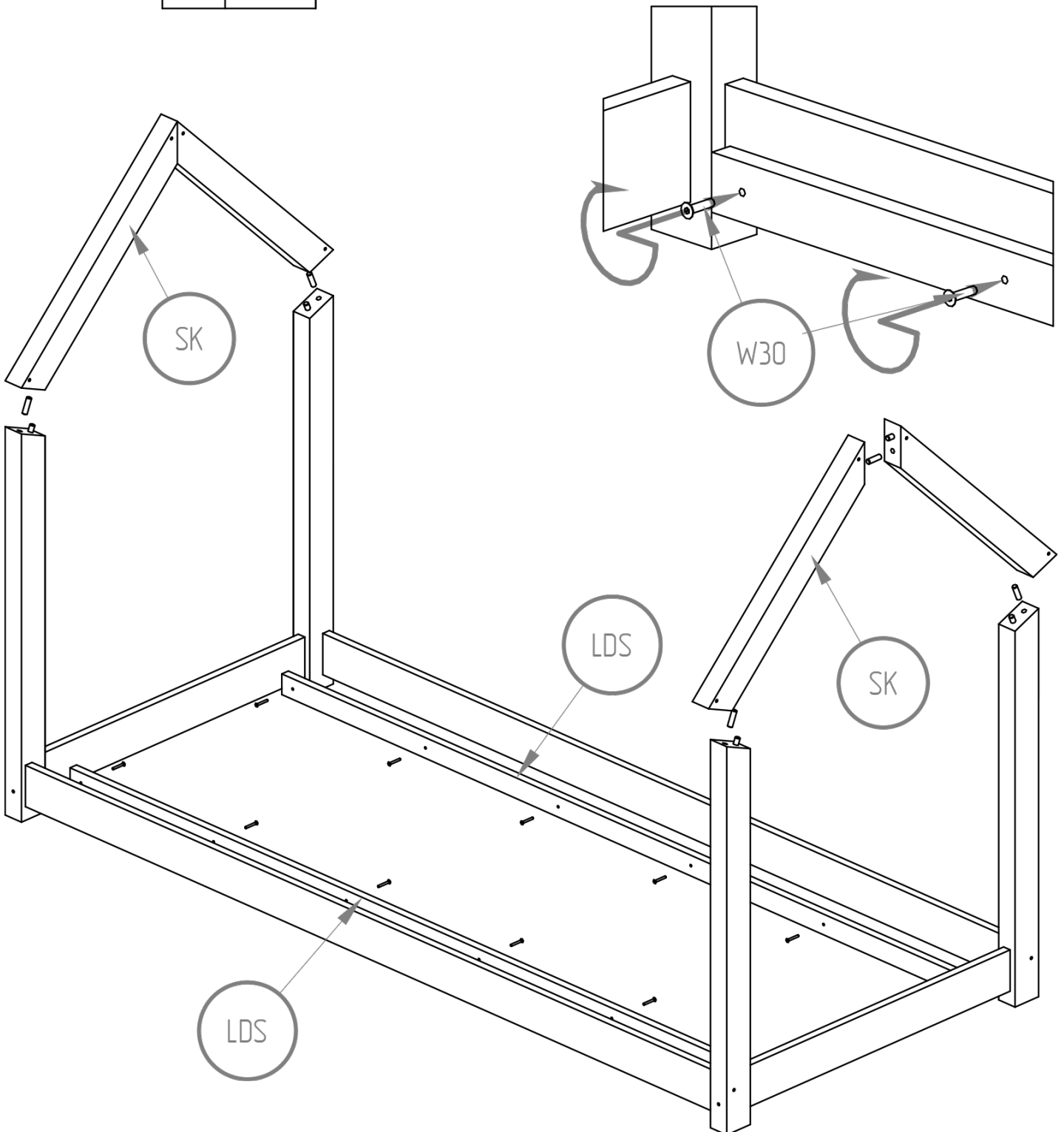

B2 - x1
LD - x2
LKS - x1
S80 - x8
W30 - x2

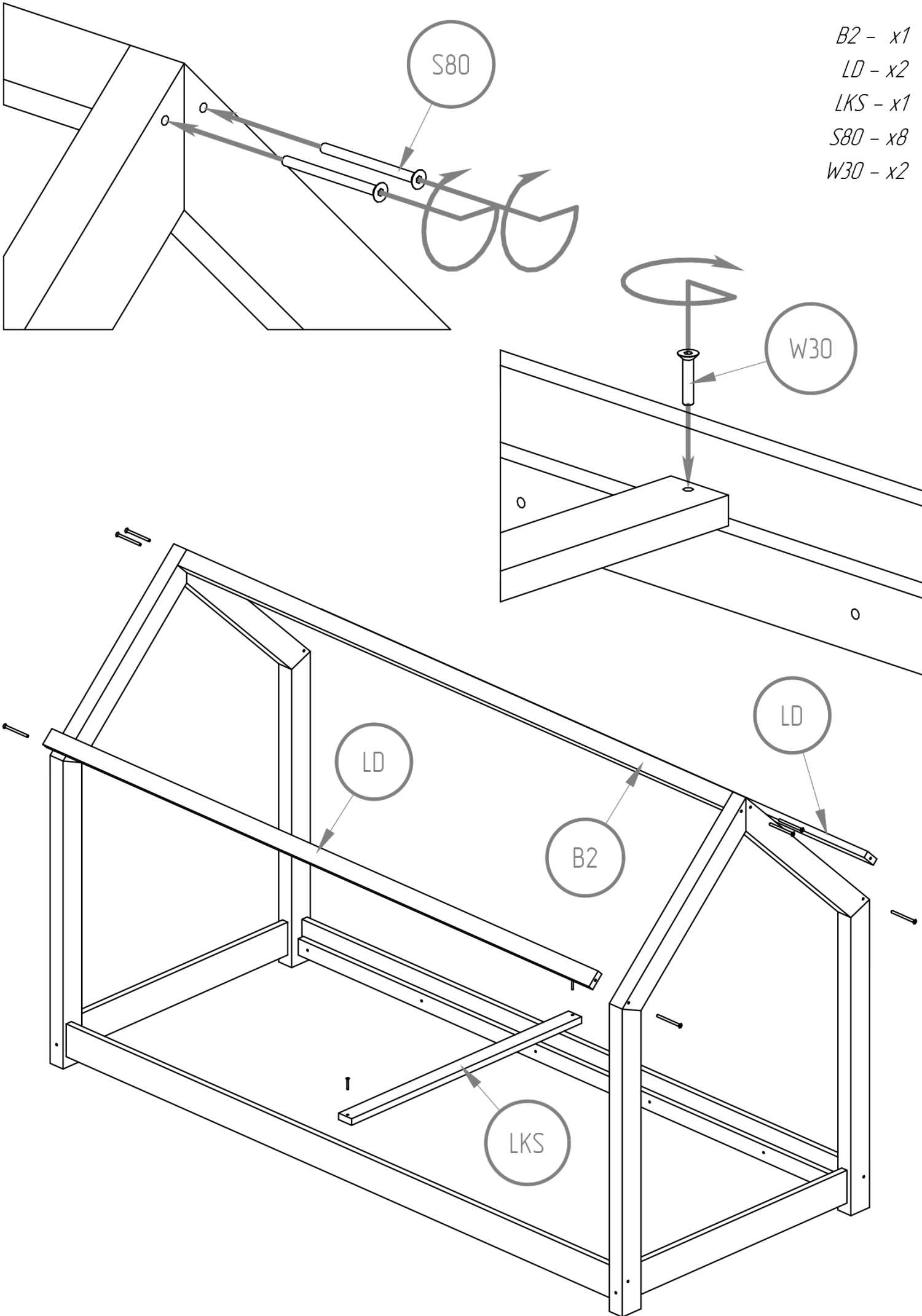

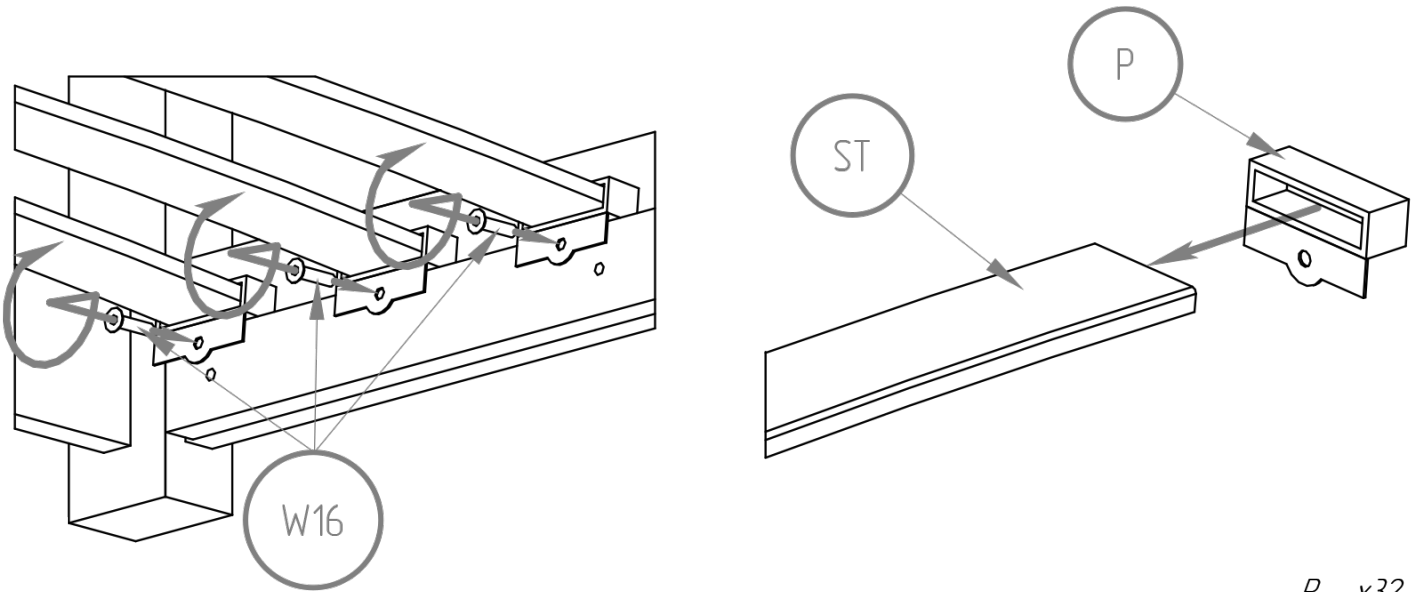

P - x32
ST - x16
W16 - x32

